

Assembly Instructions ■

Center Drawer

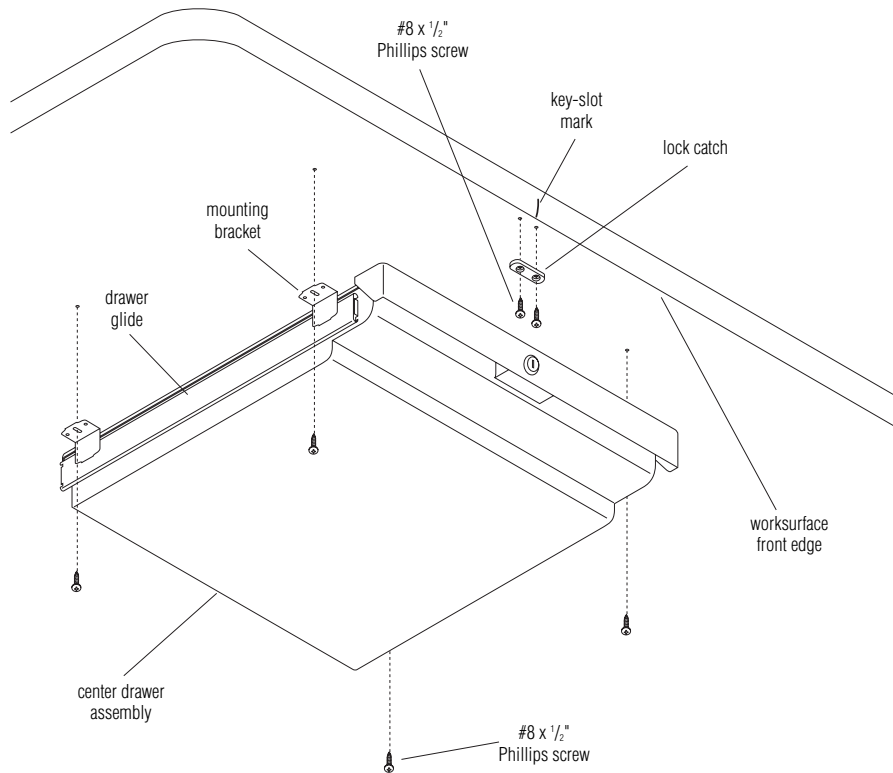

1. Begin installation of the center drawer by making sure the glides on each side of the drawer are snapped in the closed position. Find and remove the hardware pack which is taped to the inside of the drawer.
2. Position the unit under the worksurface at the desired location, with the front edge of the drawer being flush with the front edge of the worksurface. Using a pencil, mark the worksurface at the center slots of the four mounting brackets.
3. If drawer is equipped with a lock mechanism, a lock catch will need to be mounted above the key slot, on the underside of the worksurface. To help locate the catch, make a pencil mark on the front edge of the worksurface above the key slot location as illustrated. Make the mark while the drawer is held up in the position where it will be mounted. Set the drawer aside until step 7.
4. Center the lock catch at the key-slot mark and hold it flush with the front edge of the worksurface. Make marks to the worksurface through the mounting holes in the lock catch.
5. Drill four pilot holes not more than $\frac{1}{2}$ " deep using a $\frac{1}{16}$ " drill bit at the locations marked for mounting the drawer to the underside of the worksurface. If drawer is to be equipped with a locking mechanism, drill the two holes for the lock catch as described above.
6. Secure the lock catch to the worksurface with two $\#8 \times \frac{1}{2}$ " Phillips screws as illustrated. Wipe the location mark off the front edge of the worksurface.
7. Position the center drawer over the pilot holes in the worksurface and secure with four $\#8 \times \frac{1}{2}$ " Phillips screws.